

# MORLINKOM TECHNOLOGY LTD.

## SCHEMATIC

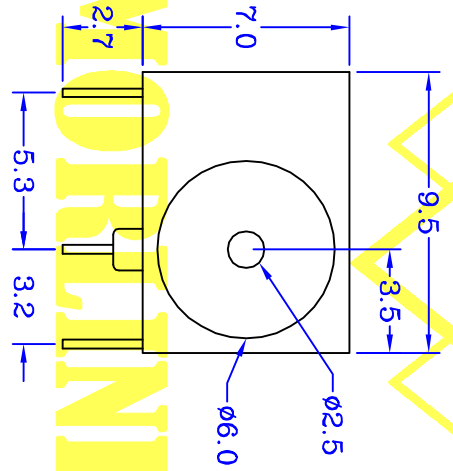

## PCB LAYOUT

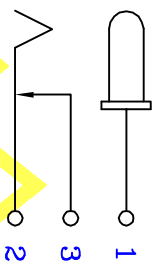
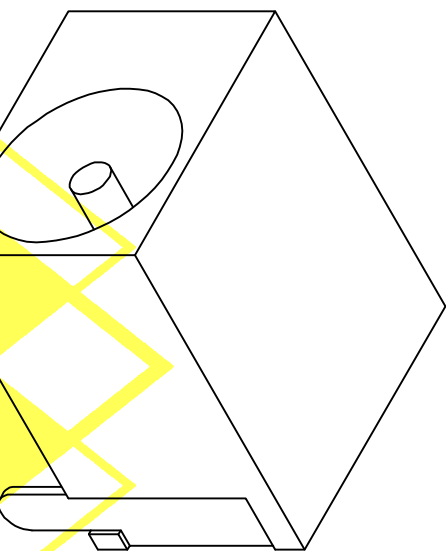
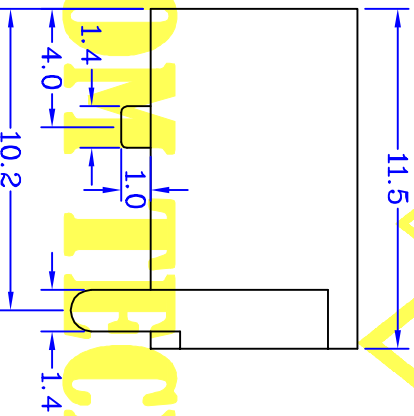
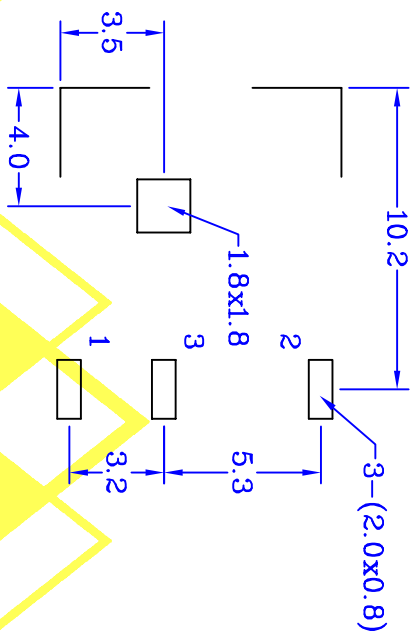

## SPECIFICATIONS

### ELECTRICAL

- Contact Current Rating : 2A 12V DC / 0.5A 30V DC
  - Contact Resistance : 30 mΩ Max
  - Insulator Resistance : 100 MΩ Min
  - Dielectric Withstanding Voltage : 500 V AC RMS 60 Seconds
  - Operating Voltage : 150V AC Max
- MECHANICAL**
- Insertion & Extraction Force:
  - Initial : 0.3 To 3.0 Kgs
  - After life test : 0.2 To 3.0 Kgs
  - life test (20-30 cycle/minute) 500 cycles unloading

UNIT : mm

CENTRONIC PRECISION ELECTRONIC COMPANY

MORLINKOM TECHNOLOGY LTD

三川精密電子有限公司

魔林科技有限公司

TEL:886-2-2686-8788

FAX:886-2-2686-0018

E-MAIL: Centron@tp6.seed.net.tw

E-MAIL: Cen8888@gmail.com

繪圖	DRAWN BY	日期	DATE
核對	FUFU	2009/10/26	
CHECKED BY	WENDY	比例	SCALE
		1:1	

DCPJ-2.5-WTJ

圖號 851-16  
DRAWING NO.